



Rewarding Learning

General Certificate of Secondary Education
2023

Centre Number

--	--	--	--	--

Candidate Number

--	--	--	--	--

Technology and Design

Unit 2

Option B:

Mechanical and Pneumatic
Control Systems



[GTY22]

GTY22

TUESDAY 20 JUNE, MORNING

TIME

1 hour 30 minutes.

INSTRUCTIONS TO CANDIDATES

Write your Centre Number and Candidate Number in the spaces provided at the top of this page.

You must answer the questions in the spaces provided.

Do not write outside the boxed area on each page or on blank pages.

Questions which require drawing or sketching should be completed using an H.B. pencil.

All other questions must be completed using black ink only.

Do not write in pencil or with a gel pen.

Answer **both** questions.

INFORMATION FOR CANDIDATES

The total mark for this paper is 100.

Quality of written communication will be assessed in Question **2(f)**.

Figures in brackets printed down the right-hand side of pages indicate the marks awarded to each question or part question.

The Formula sheet is on page 3.

13431



20GTY2201

BLANK PAGE
DO NOT WRITE ON THIS PAGE
(Questions start on page 4)

13431



20GTY2202



Formulae for GCSE Technology and Design

You should use, where appropriate, the formulae given below when answering questions which include calculations.

1 Gear ratio of a simple gear train = $\frac{\text{number of teeth on driven gear}}{\text{number of teeth on driver gear}}$

For a compound gear train:

Total Gear ratio = the product of the gear ratios of all the subsystems

i.e. $GR_T = GR_1 \times GR_2 \times GR_3 \dots$

2 Velocity Ratio = $\frac{\text{Distance moved by effort}}{\text{Distance moved by load}}$ or $\frac{\text{Diameter of driven}}{\text{Diameter of driver}}$

3 Mechanical Advantage = $\frac{\text{Load}}{\text{Effort}}$

4 Efficiency (%) = $\left(\frac{\text{mechanical advantage}}{\text{velocity ratio}} \right) \times 100$

5 Force = Pressure \times Area ($F = P \times A$)

6 Circumference of a circle = $\pi \times \text{diameter}$

7 Area of a circle = πr^2

[Turn over





Answer All Questions

- 1 (a) Complete **Table 1** by naming each of the mechanical symbols and insert the appropriate letter from the list opposite to describe its function.

Each letter may be used only once.

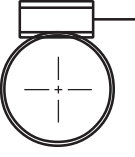
Table 1

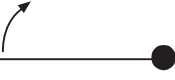
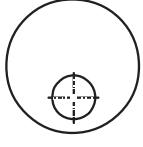
Mechanical Symbol	Name of Symbol	Function
		
		
		
		
		

[10]



Function

- A To enable the output to rise and fall.
- B To change linear motion to rotary motion or vice versa.
- C To change rotary motion to linear motion.
- D To make a large speed reduction and increase torque.
- E To provide a mechanical advantage to lift heavy loads.

[Turn over

13431



20GTY2205

(b) Fig. 1 below shows a sprocket and chain system which connects an electric motor to a machine.

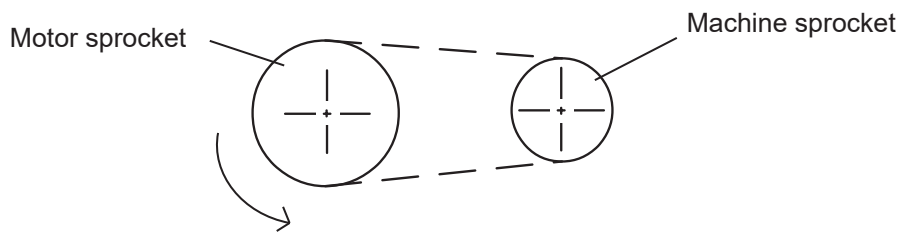

Fig. 1

Complete each of the following by placing a tick in the correct box.

(i) The machine sprocket rotates:

Clockwise

Anticlockwise

[1]

(ii) The teeth on the motor sprocket are:

Larger than the teeth on the machine sprocket

The same size as the teeth on the machine sprocket

[1]

(iii) The machine sprocket is the:

Low speed sprocket

High speed sprocket

[1]



(iv) Outline **two** advantages of a sprocket and chain system.

[2]

(v) Outline **two** disadvantages of a sprocket and chain system.

[2]

(vi) If the motor sprocket has **80** teeth and the machine sprocket has **20** teeth, calculate the velocity ratio of the system.

Candidates need to show their working out in the space below.

Answer _____ [3]

[Turn over



- (c) A compound gear train shown in **Fig. 2** has two pairs of meshed gears: **A** and **B**, and **C** and **D**. Gear **A** has 30 teeth, gear **B** has 20 teeth, gear **C** has 40 teeth and gear **D** has 20 teeth. The driver gear **A** rotates at 1240RPM.

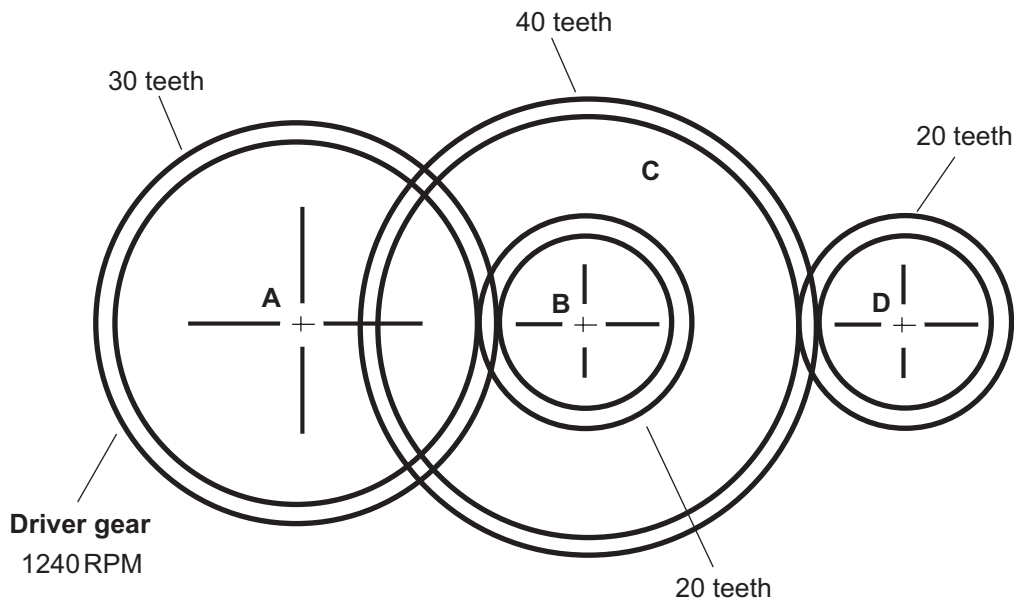

Fig. 2

- (i) Calculate the gear ratio of the gear train.

Candidates need to show their working out in the space below.

Answer _____ [6]



(ii) Calculate the output velocity of driven gear D.

Candidates need to show their working out in the space below.

Answer _____ [3]

13431

[Turn over



20GTY2209

(d) Fig. 3 shows a machine which is used to press out discs from sheets of material.

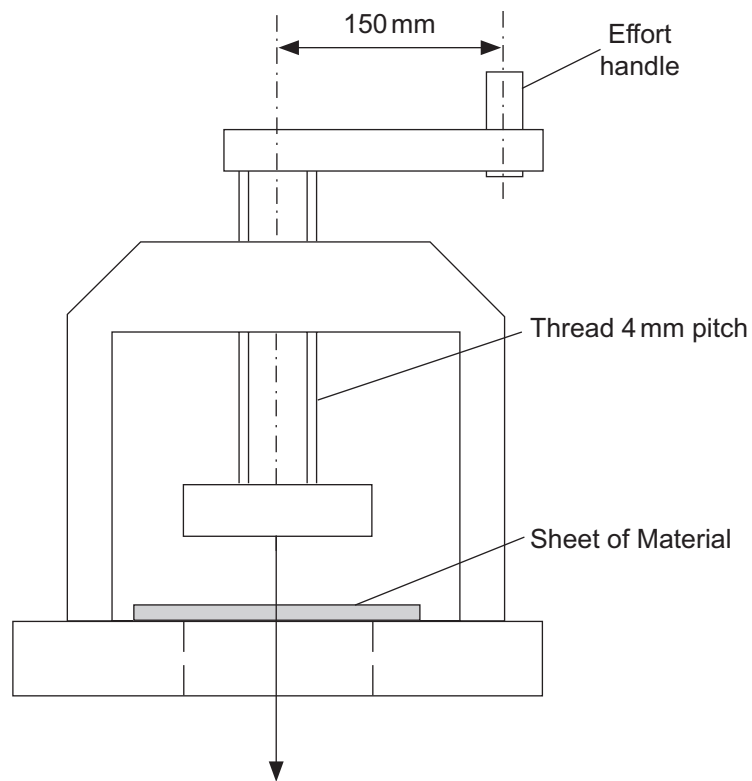

Fig. 3

(i) The press uses a screw thread.

Give **two** other examples where a screw thread is used to produce a large force.

1. _____ [1]

2. _____ [1]



- (ii) The mechanical advantage of the press is 50.
Calculate the effort required to produce a press force of 8 kN.

Candidates need to show their working out in the space below.

Answer _____ [4]

- (iii) Calculate the velocity ratio of the press.

Candidates need to show their working out in the space below.

Answer _____ [5]

- (iv) Suggest **two** ways in which the design of the press could be modified to increase the velocity ratio.

1. _____ [2]

2. _____ [2]

[Turn over



- (v) The effort handle has to be securely fixed to the machine but it has to be allowed to rotate with the person's hand when they are turning it. Show with the aid of a detailed annotated sketch or sketches how this could be successfully done.

[6]

13431



20GTY2212





BLANK PAGE

DO NOT WRITE ON THIS PAGE

(Questions continue overleaf)

13431





[Turn over



20GTY2213

2 Table 2 shows the symbols for some pneumatic components.

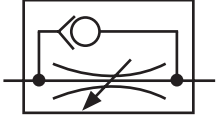
Table 2

Symbol	Name of Symbol
	
	
	
	
	

[5]

(a) Complete Table 2 by inserting the correct name for each symbol from Table 3.

Table 3

Pressure Source
Roller Trip
Pilot Pressure
Unidirectional Flow Restrictor
Double Acting Cylinder
Working Line, Return and Feed Line
Pipeline Junction



(b) Fig. 4 below shows three pneumatic valves which could be used to operate a machine. The machine can be operated in two ways:

By pressing valves **A** and **B**

Or

By pressing valve **C**.

Complete the circuit in Fig. 4 to show how this could be achieved.

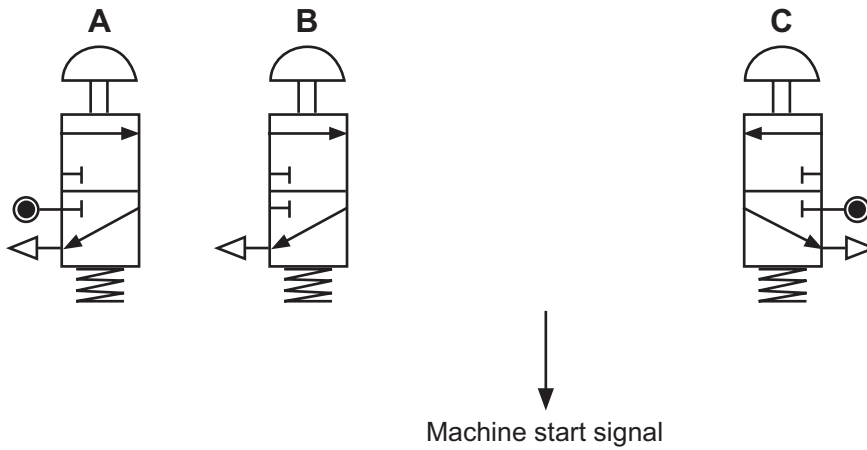

Fig. 4

[4]



(c) Fig. 5 shows a pneumatic circuit.

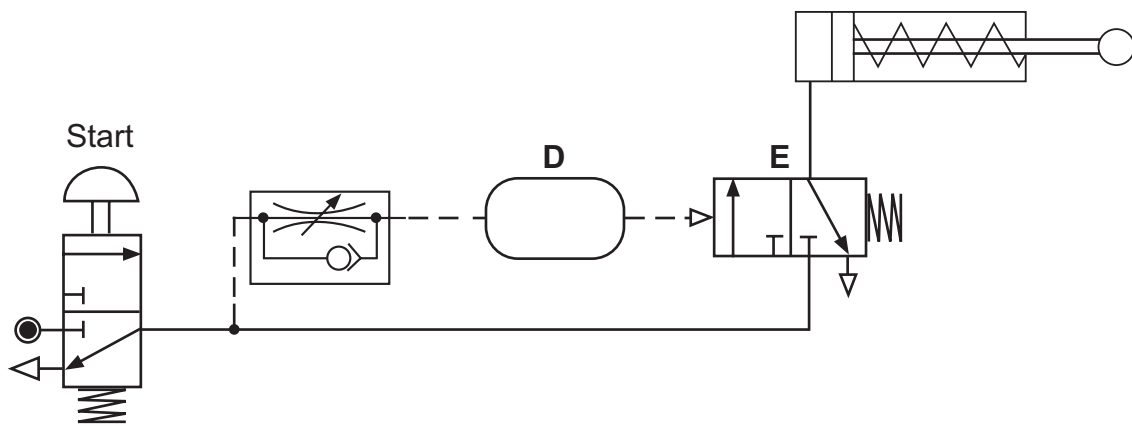

Fig. 5

(i) Name the components labelled **D** and **E**.

D _____

E _____ [2]

(ii) Explain how the circuit operates when the start button is pressed and held in and then let go.

_____ [4]



(d) Fig. 6 shows a pneumatic circuit.

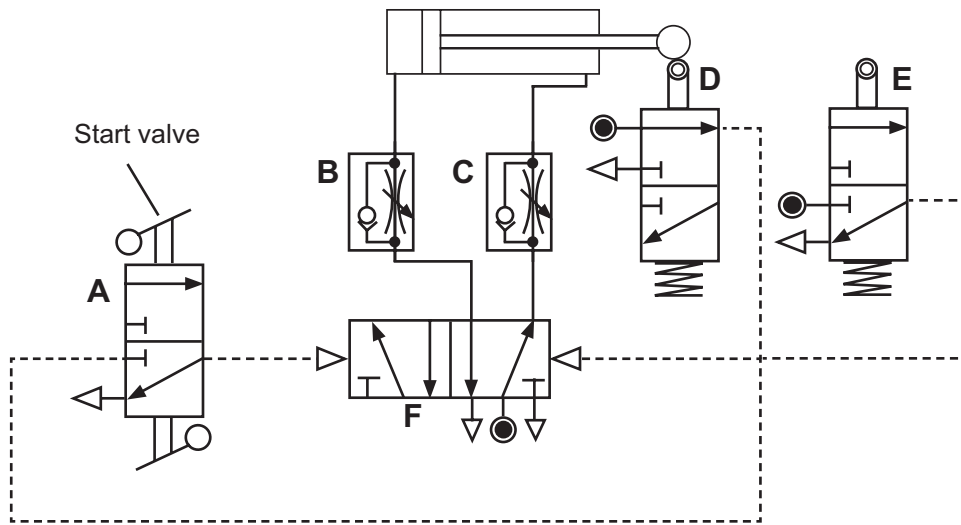

Fig. 6

- (i) The cylinder's piston has a cross-sectional area of 500 mm^2 and the cross-sectional area of the piston rod is 100 mm^2 .

Supply pressure = 0.4 N/mm^2

Calculate the force the cylinder can exert on the instroke.

Candidates need to show their working out in the space below.

Answer _____ [4]

- (ii) Describe the operation of the circuit when the start valve is operated.

[4]

[Turn over



(iii) Which valve controls the speed of the instroke of the cylinder?

_____ [1]

(iv) Explain how the stroke of the cylinder in this circuit can be adjusted.

_____ [2]

(e) Fig. 7 shows an incomplete pneumatic circuit.

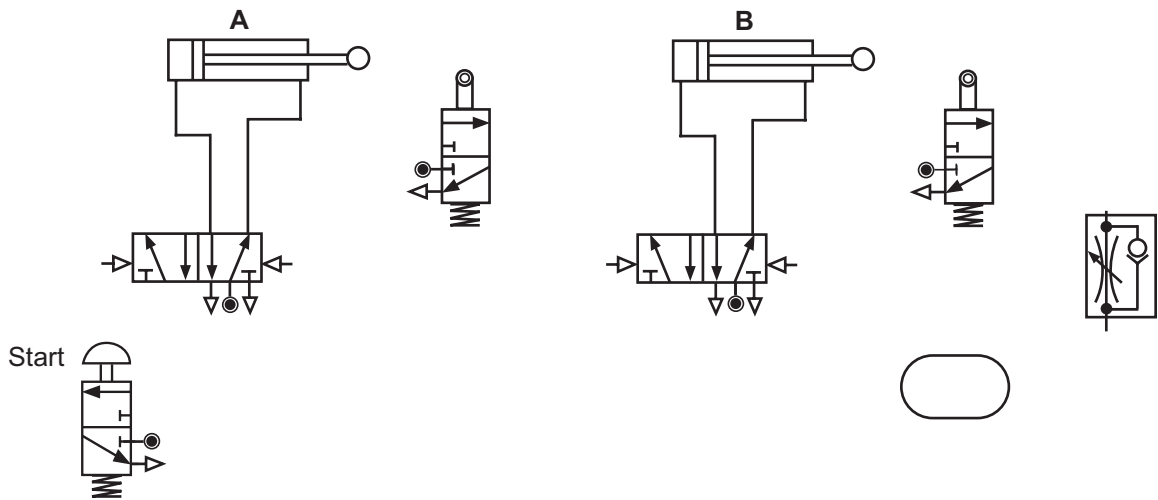

Fig. 7

When the start button is pressed for a brief moment the cylinders are to move in the following sequence:

- Cylinder **A** outstrokes.
- When the outstroke of cylinder **A** is confirmed, cylinder **B** outstrokes.
- When the outstroke of cylinder **B** is confirmed, cylinders **A** and **B** instroke after a short time period.

Complete Fig. 7, showing the connecting pipes and additional valves needed, for the circuit to operate in this sequence.

[12]



(f) Outline **three** different everyday applications where pneumatic products are used. In each case, describe its function and justify the selection of pneumatics in these particular applications.

Quality of written communication will be assessed in this question.

Application 1: _____

Application 2: _____

Application 3: _____

[12]

THIS IS THE END OF THE QUESTION PAPER



DO NOT WRITE ON THIS PAGE

For Examiner's use only	
Question Number	Marks
1	
2	

Total Marks	
--------------------	--

Examiner Number

Permission to reproduce all copyright material has been applied for.
In some cases, efforts to contact copyright holders may have been unsuccessful and CCEA
will be happy to rectify any omissions of acknowledgement in future if notified.

GTY22/5
277042



20GTY2220